

NORTHSTAR[★] CORE 4.8

Specifications

Length	4.78 m.
Beam	1.97 m.
Maximum Payload	720 kg.
Empty Weight	270 kg.
Maximum Persons	8 pax
Tube Diameter	0.50 m.
Suggested Tube Pressure	0.18 bar / 2.6 psi
No. of Chambers	4
Maximum Power	85 HP
Recommended Power	60 HP
Shaft Length	L
Fuel Tank Capacity	-
Design Category	CE - Cat. C

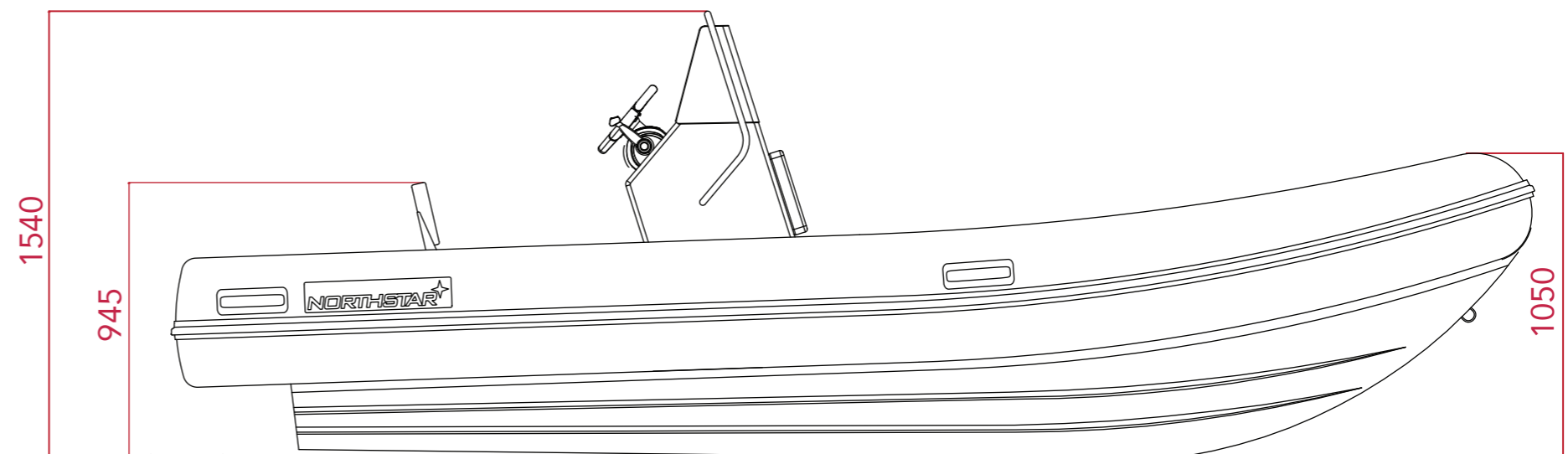
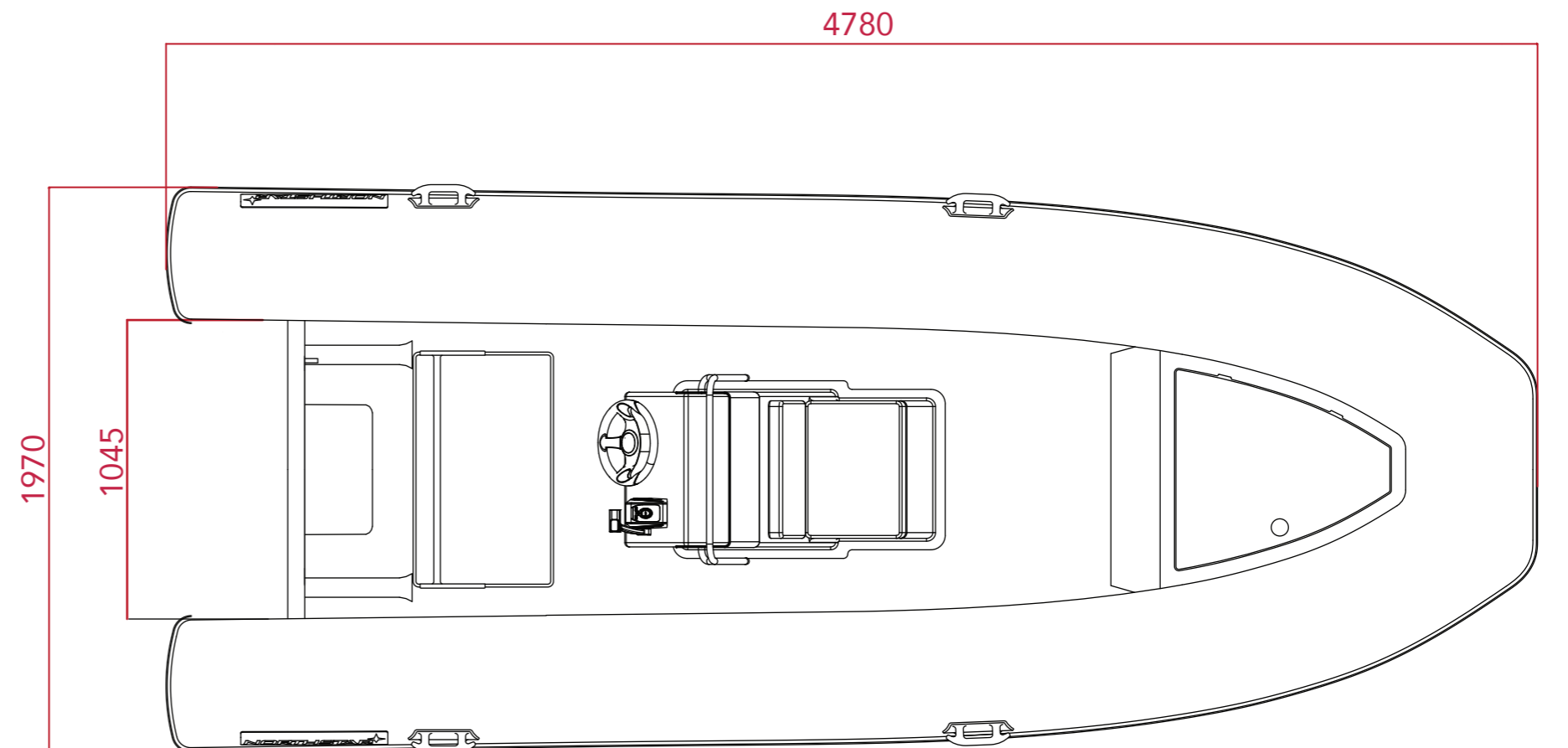

measurements in mm