

NORTHSTAR[★] CORE 8

Specifications

Length	8 m. / 26'2"
Beam	2.8 m. / 9'2"
Max Payload	1800 kg. / 3970 lbs
Empty Weight	1420 kg. / 3130 lbs
Maximum Persons	14 pax
Tube Diameter	56 cm. / 22"
Suggested Tube Pressure	0.18 bar / 2.6 psi
No. of Chambers	7
Maximum Power	350 HP
Recommended Power	300 HP
Shaft Length	XXL / 2 XL
Fuel Tank Capacity	450 lt. / 118 US Gal
Design Category	CE - Cat. B

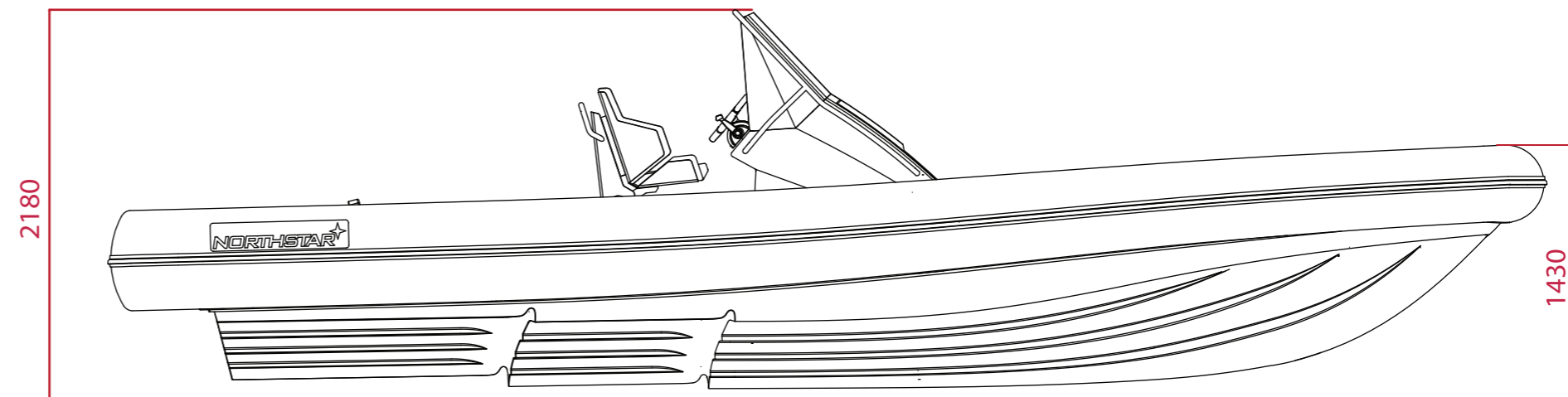
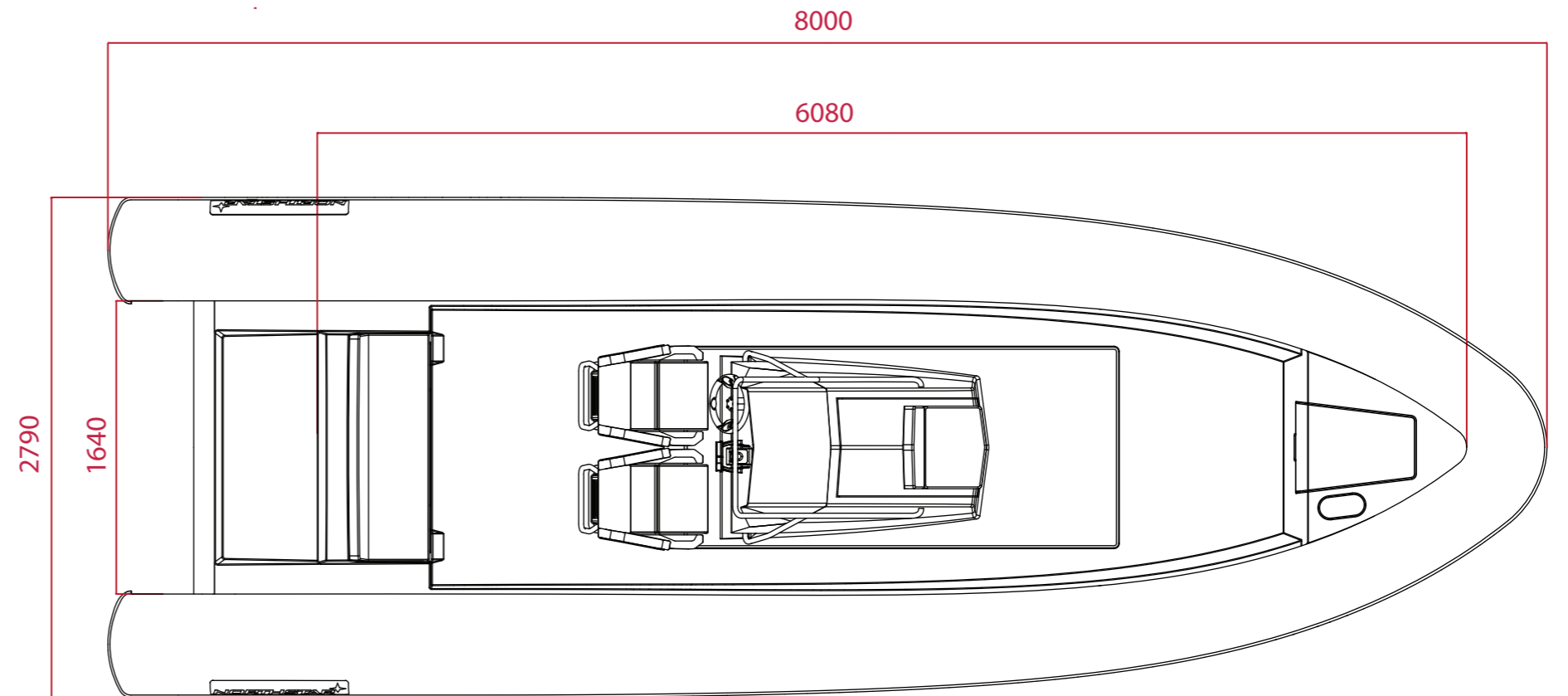

measurements in mm