

NORTHSTAR[★] AXIS 3.1

Specifications

Length	325 cm. / 10'7"
Beam	181 cm. / 5'11"
Weight	210 kg. / 462 lbs
Tube Diameter	0.40 m. / 15.7"
Suggested Tube Pressure	0.18 bar / 2.6 psi
No. of Chambers	3
Maximum Persons	4
Minimum Power	20 HP
Maximum Power	30 HP
Recommended Power	25 HP
Shaft Length	S / L
Fuel Tank Capacity	33 lt. / 8.7 US Gal
Design Category	CE - Cat. C

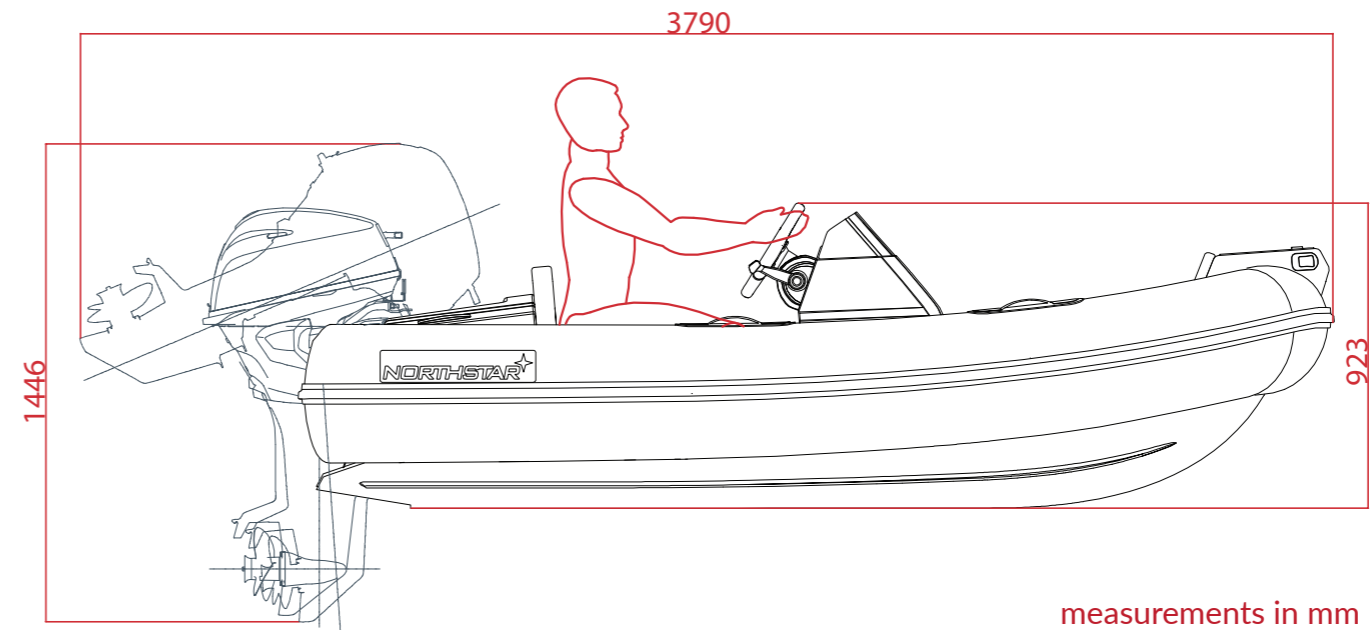
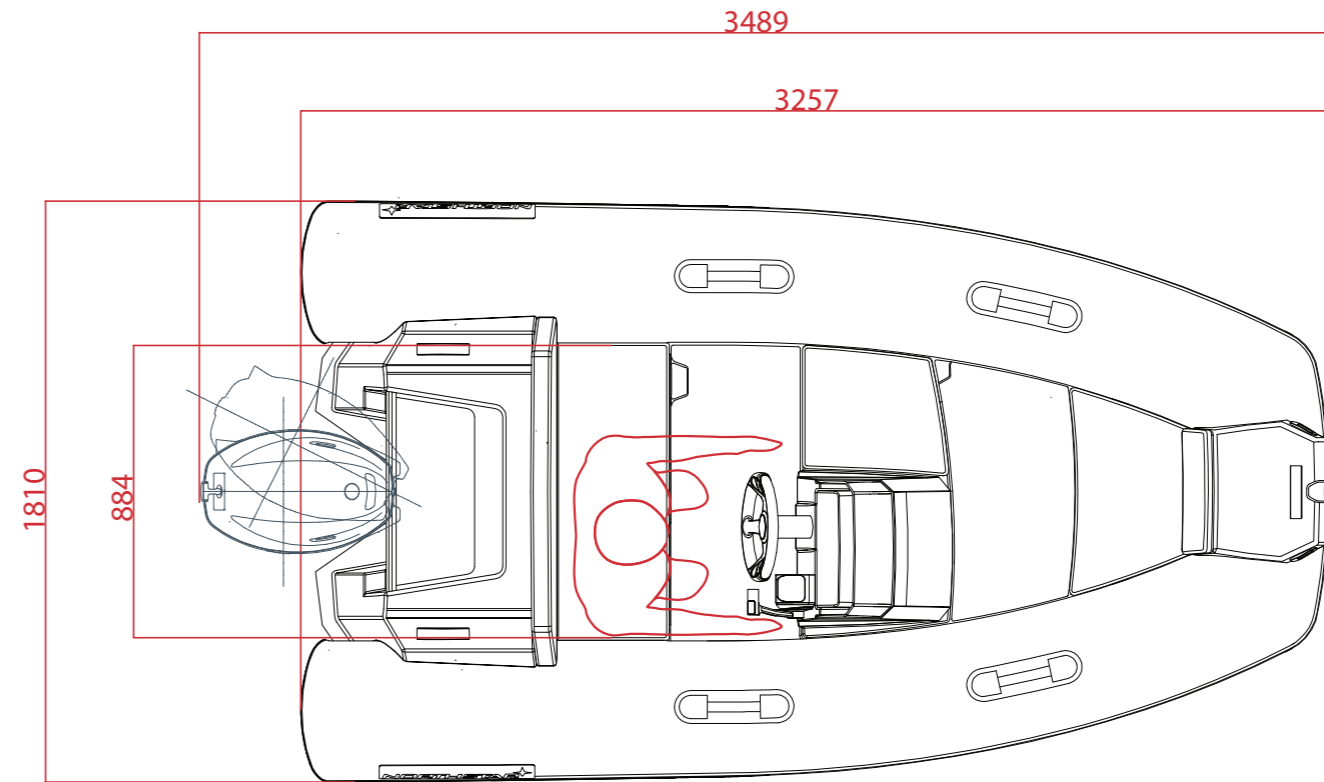

measurements in mm

NORTHSTAR⁺ AXIS 3.4

Specifications

Length	340 cm. / 11'2"
Beam	175 cm. / 5'9"
Weight	210 kg. / 462 lbs
Tube Diameter	0.41 m. / 16.1"
Suggested Tube Pressure	0.18 bar / 2.6 psi
No. of Chambers	3
Maximum Persons	4
Minimum Power	25 HP
Maximum Power	40 HP
Recommended Power	30 HP
Shaft Length	L
Fuel Tank Capacity	33 lt. / 8.7 US Gal
Design Category	CE - Cat. C

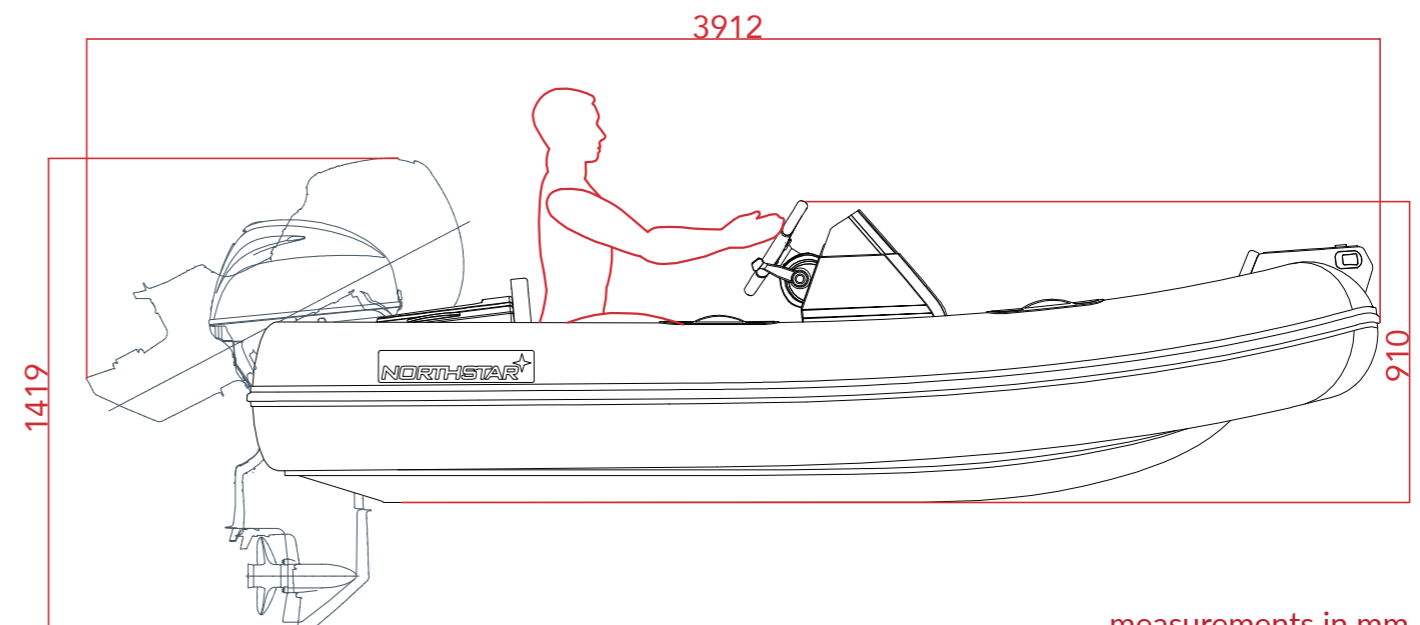
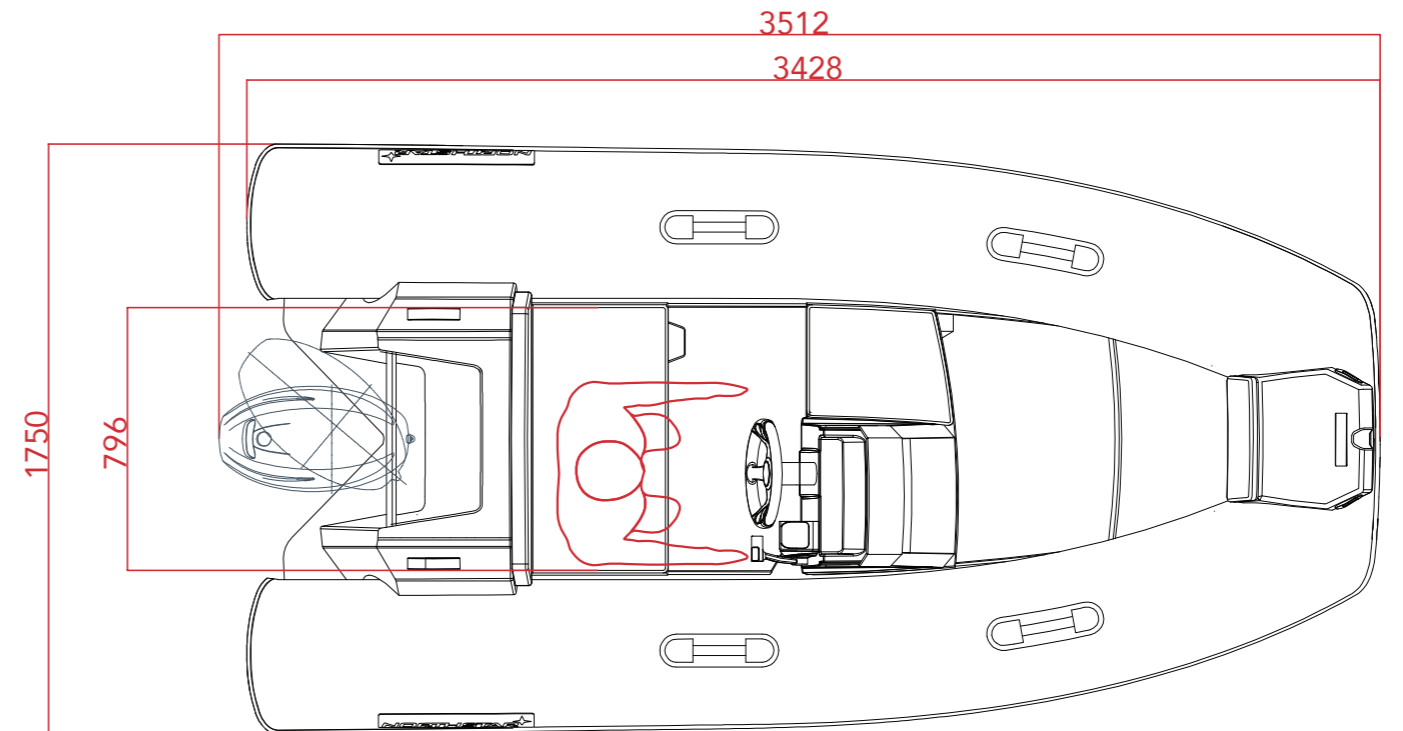

measurements in mm

NORTHSTAR AXIS 3.8

Specifications

Length	385 cm. / 12'6"
Beam	191 cm. / 6'3"
Weight	245 kg. / 540 lbs
Tube Diameter	0.43 m. / 16.9"
Suggested Tube Pressure	0.18 bar / 2.6 psi
No. of Chambers	3
Maximum Persons	5
Minimum Power	30 HP
Maximum Power	50 HP
Recommended Power	40 HP
Shaft Length	L
Fuel Tank Capacity	33 lt. / 8.7 US Gal
Design Category	CE - Cat. C

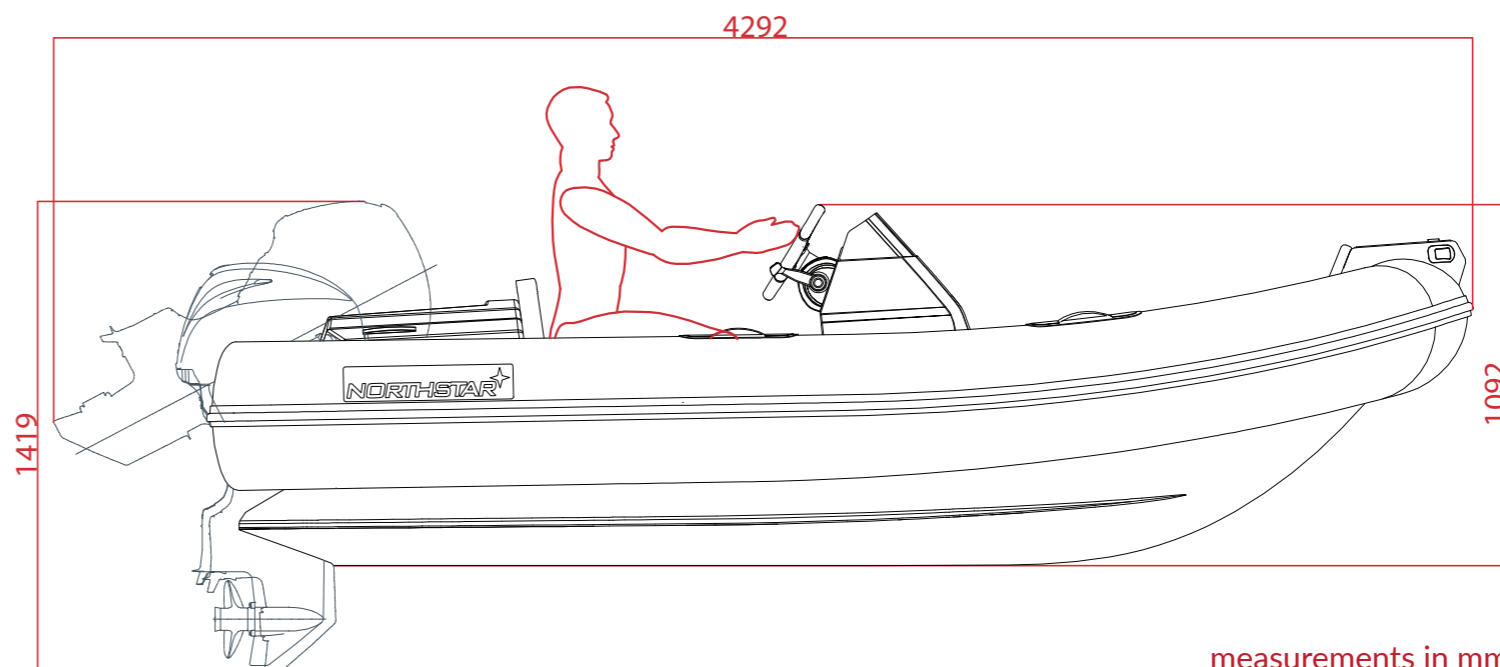
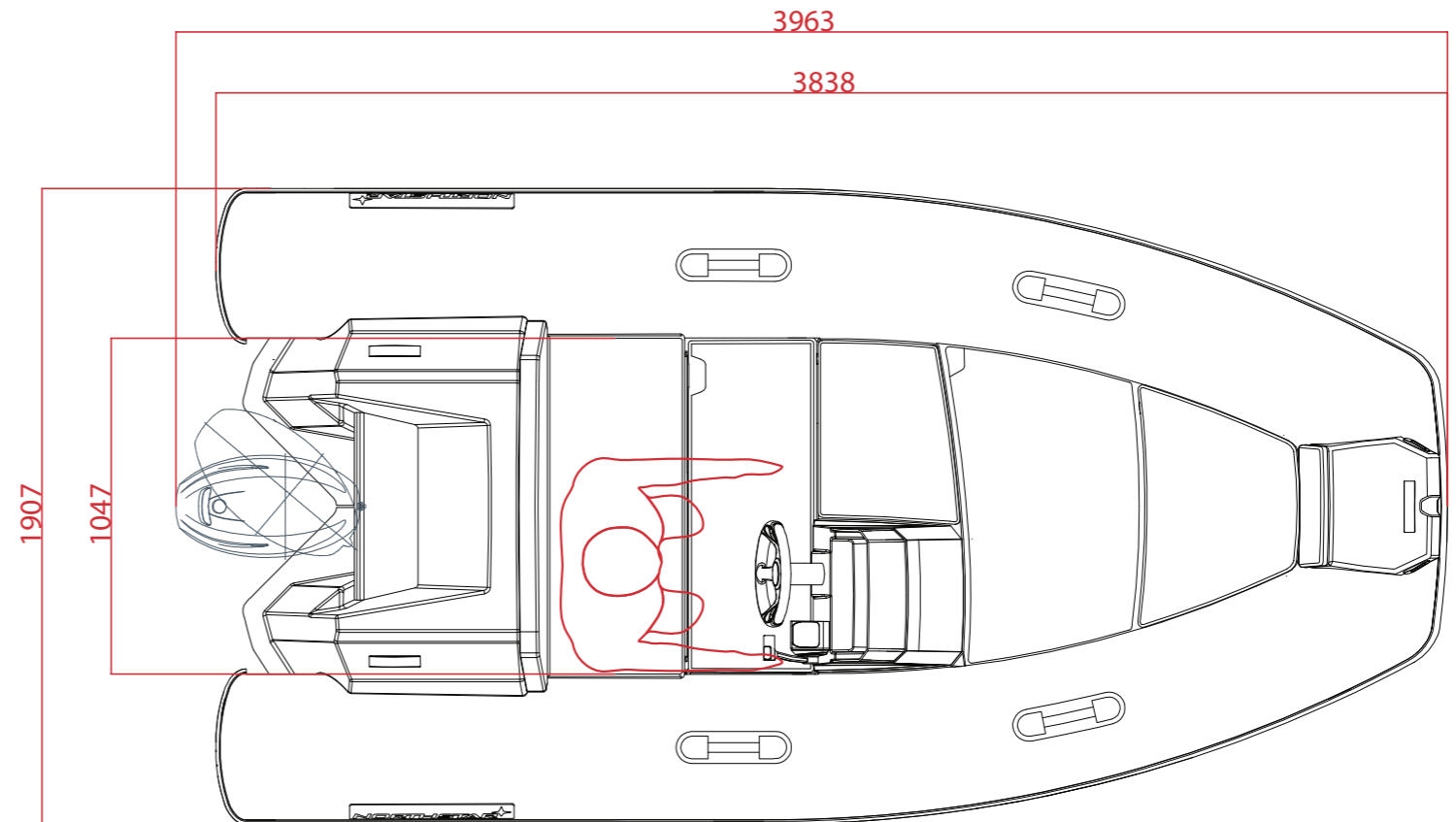

measurements in mm

NORTHSTAR⁺ AXIS 4.2

Specifications

Length	425 cm. / 13'9"
Beam	196 cm. / 6'5"
Weight	282 kg. / 621 lbs
Tube Diameter	0.43 m. / 16.9"
Suggested Tube Pressure	0.18 bar / 2.6 psi
No. of Chambers	4
Maximum Persons	6
Minimum Power	40 HP
Maximum Power	60 HP
Recommended Power	50 HP
Shaft Length	L
Fuel Tank Capacity	42 lt. / 11.1 US Gal
Design Category	CE - Cat. C

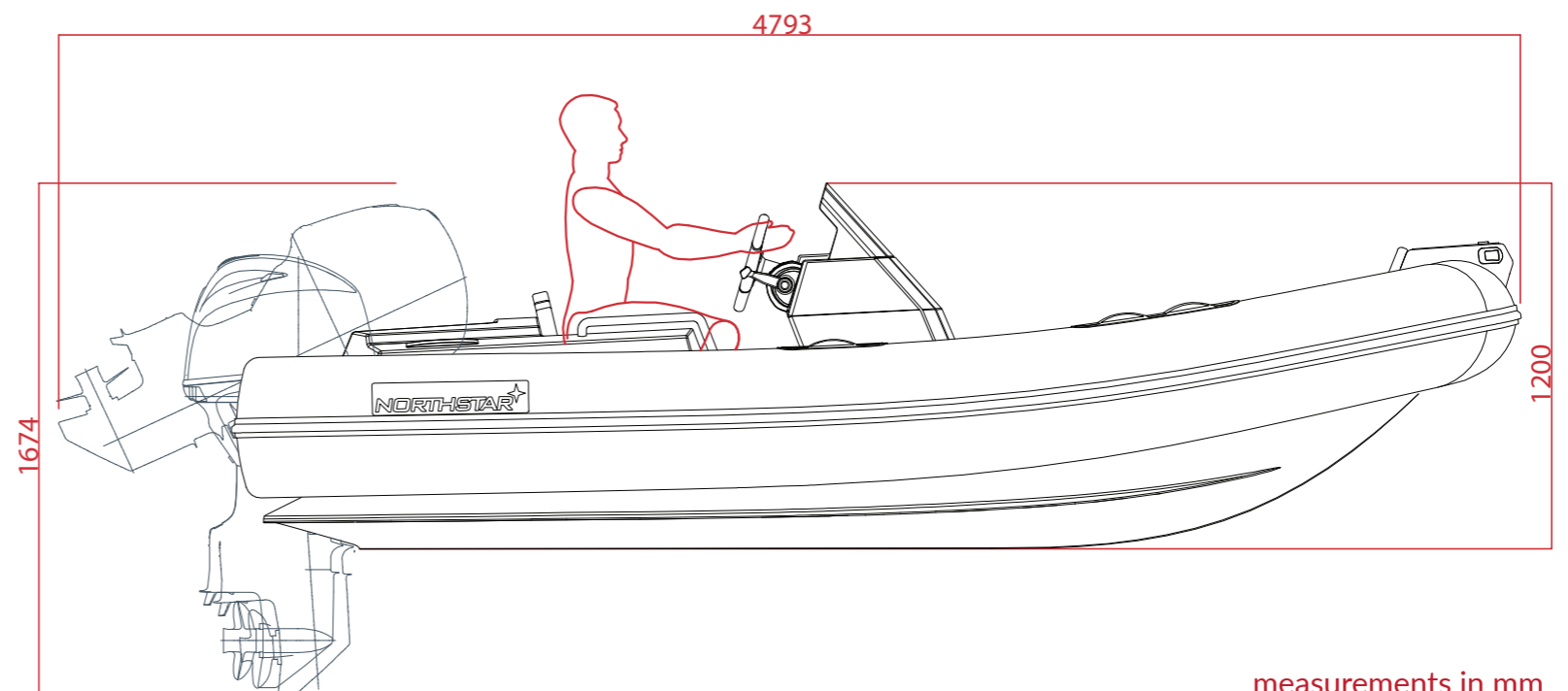
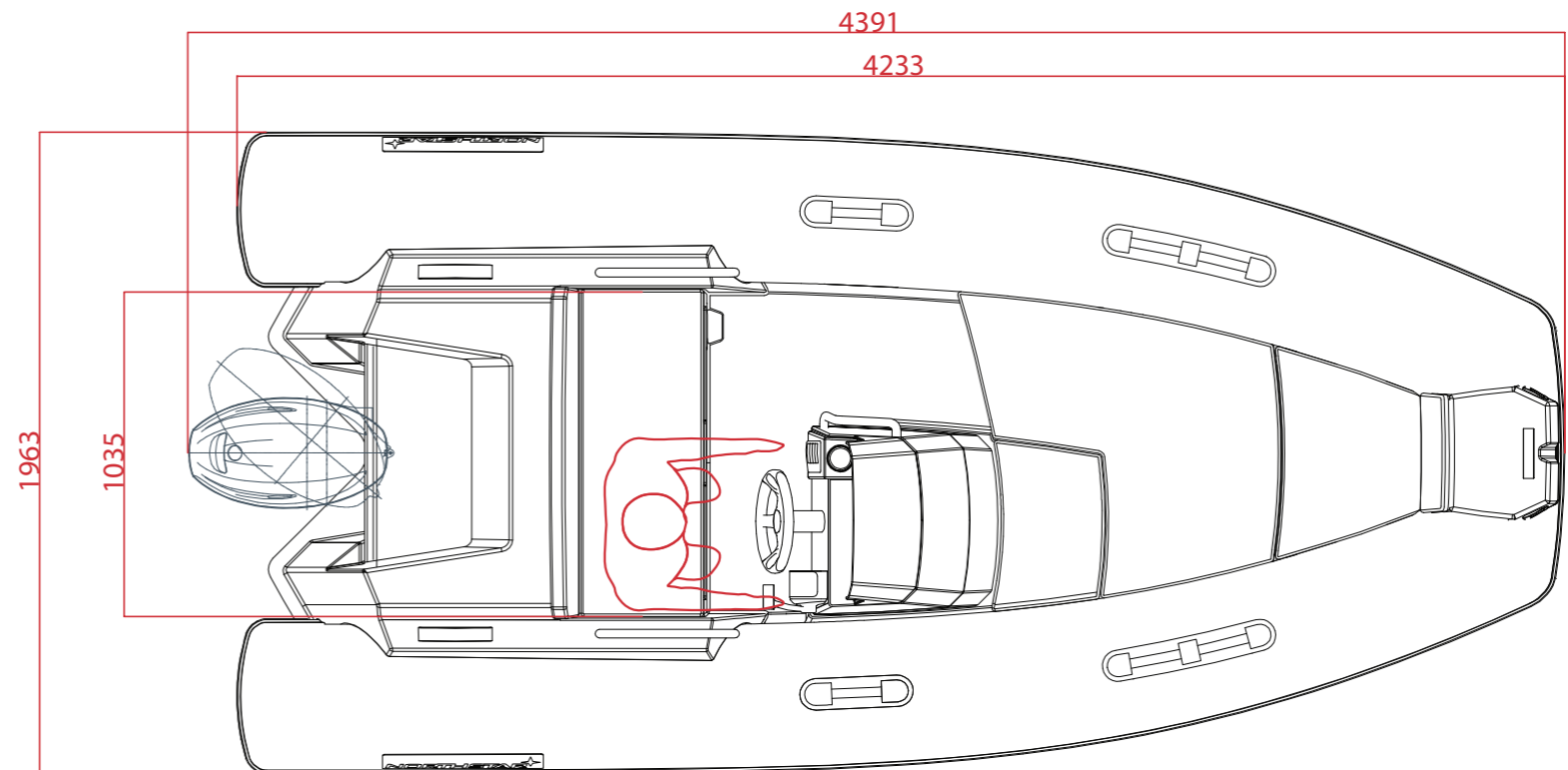

measurements in mm

NORTHSTAR⁺ AXIS 4.8

Specifications

Length	485 cm. / 15'9"
Beam	223 cm. / 7'3"
Weight	420 kg. / 925 lbs
Tube Diameter	0.46 m. / 18.1"
Suggested Tube Pressure	0.18 bar / 2.6 psi
No. of Chambers	4
Maximum Persons	8
Minimum Power	50 HP
Maximum Power	80 HP
Recommended Power	70 HP
Shaft Length	L
Fuel Tank Capacity	51 lt. / 13.5 US Gal
Design Category	CE - Cat. C

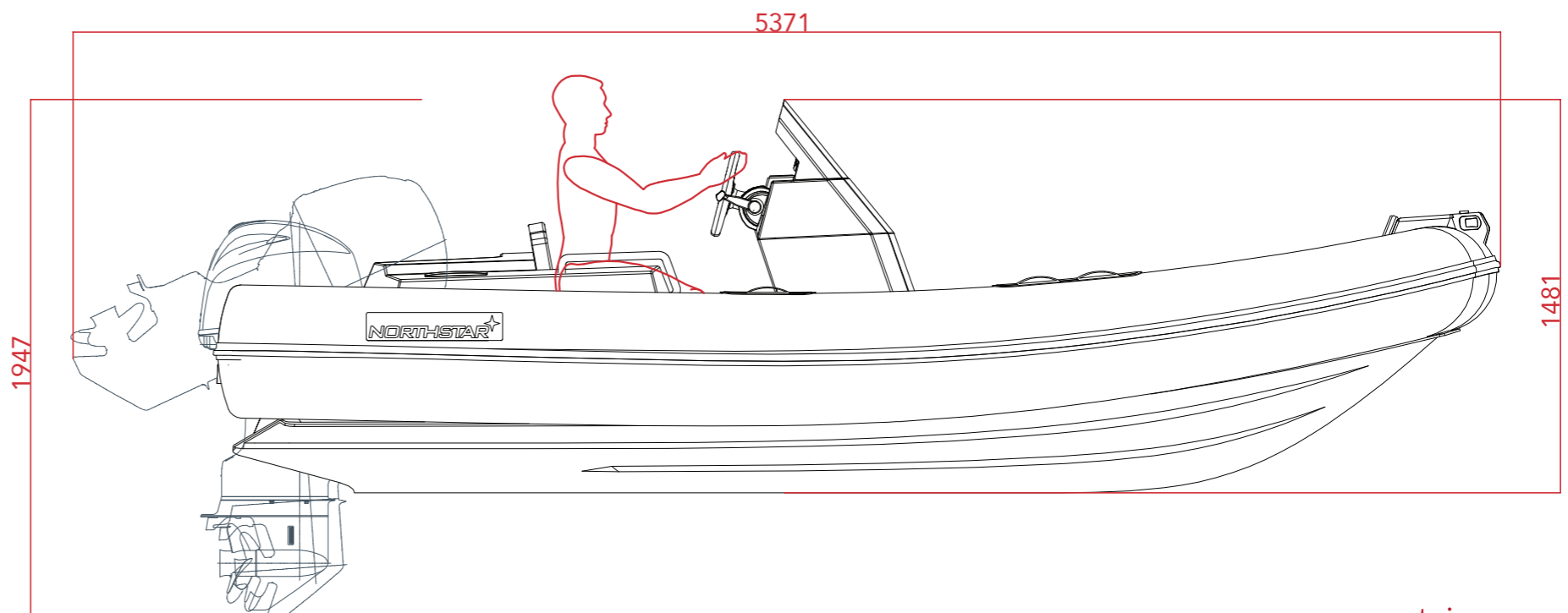
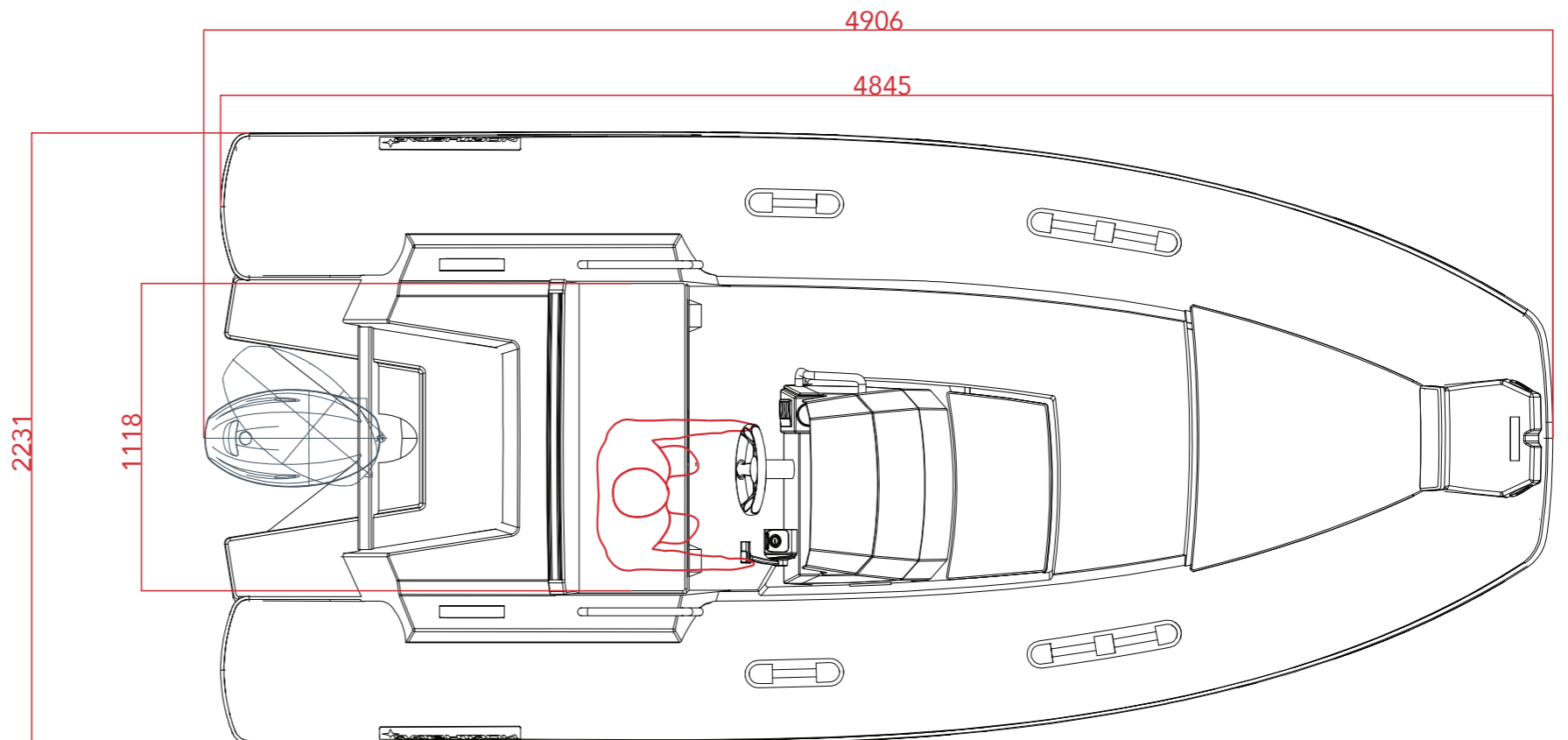

measurements in mm

NORTHSTAR AXIS 5.3

Specifications

Length	535 cm. / 17'5"
Beam	233 cm. / 7'8"
Weight	495 kg. / 1092 lbs
Tube Diameter	0.48 m. / 18.9"
Suggested Tube Pressure	0.18 bar / 2.6 psi
No. of Chambers	4
Maximum Persons	9
Minimum Power	70 HP
Maximum Power	115 HP
Recommended Power	90 HP
Shaft Length	L
Fuel Tank Capacity	62 lt. / 16.4 US Gal
Design Category	CE - Cat. C

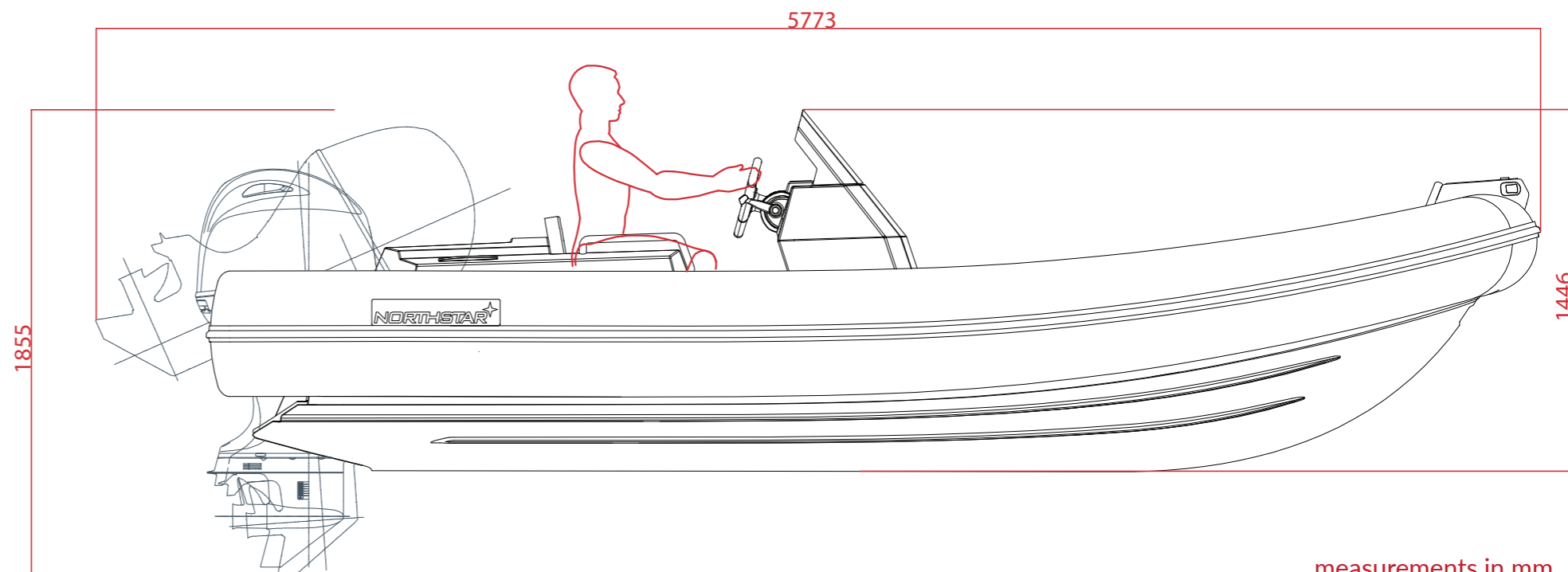
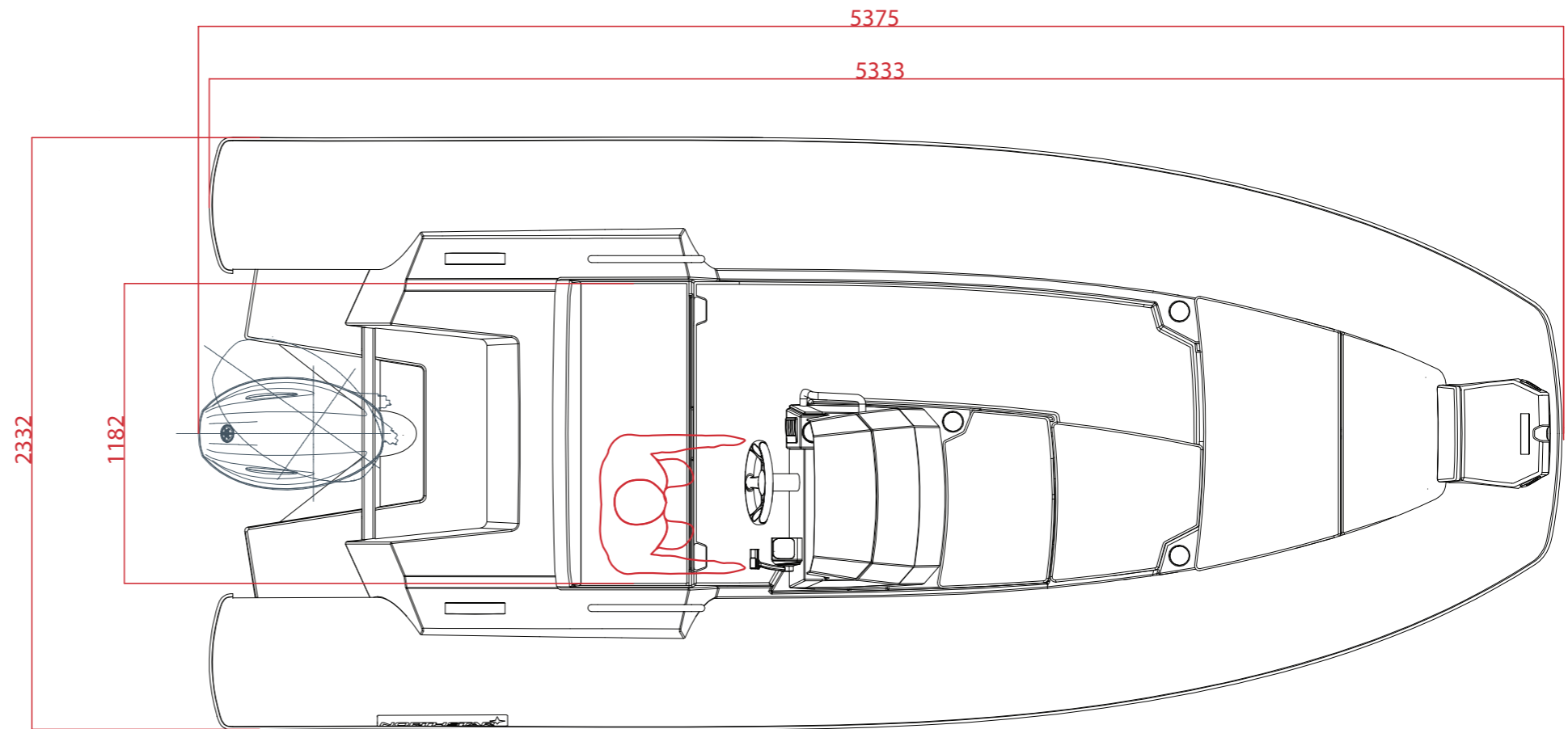

measurements in mm